

Overview & assembly manual

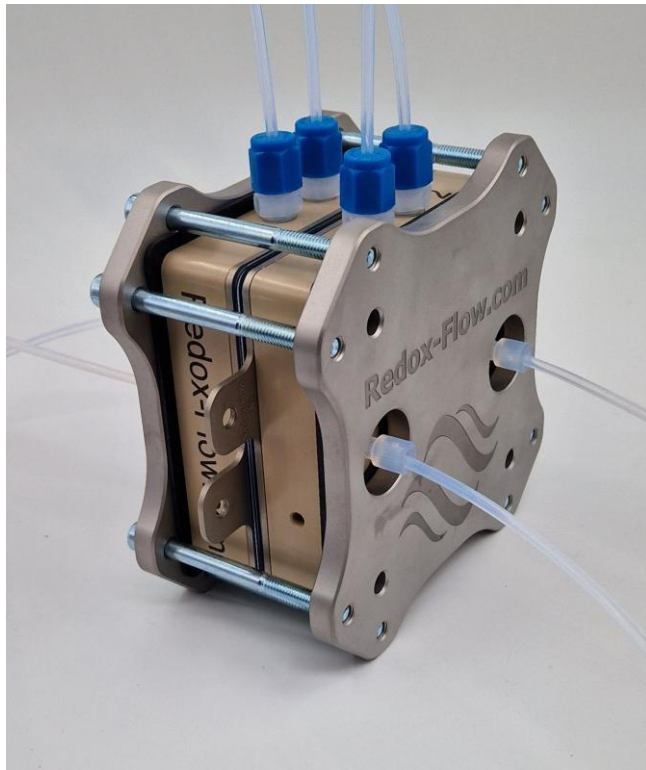

X-Cell – Electrolyser test cell

X-cell with ports for reference electrodes

Version date	March 12 - 2026
Manual version	2.2 - visit www.redox-flow.com for updated versions and spare parts
Notes	This cell is intended for research purposes only and can be used for many different purposes. There is no guarantee on performance, corrosion or lifetime on this items See https://redox-flow.com/termsandconditions/ for more information.

Overview of variants & components included – current collectors with flow field

General notes

- All gaskets are ordered separately - can be delivered in PTFE, EPDM and VITON
- All ring gaskets and O-rings in the cell package are delivered in both EPDM and VITON
- Current collector material and area is chosen with the order - Additional current collectors (area, material) and gaskets can be ordered separately whereby the cell can be used for different applications and with different active area
- Membranes and electrodes are not included in the cell package – can be ordered separately

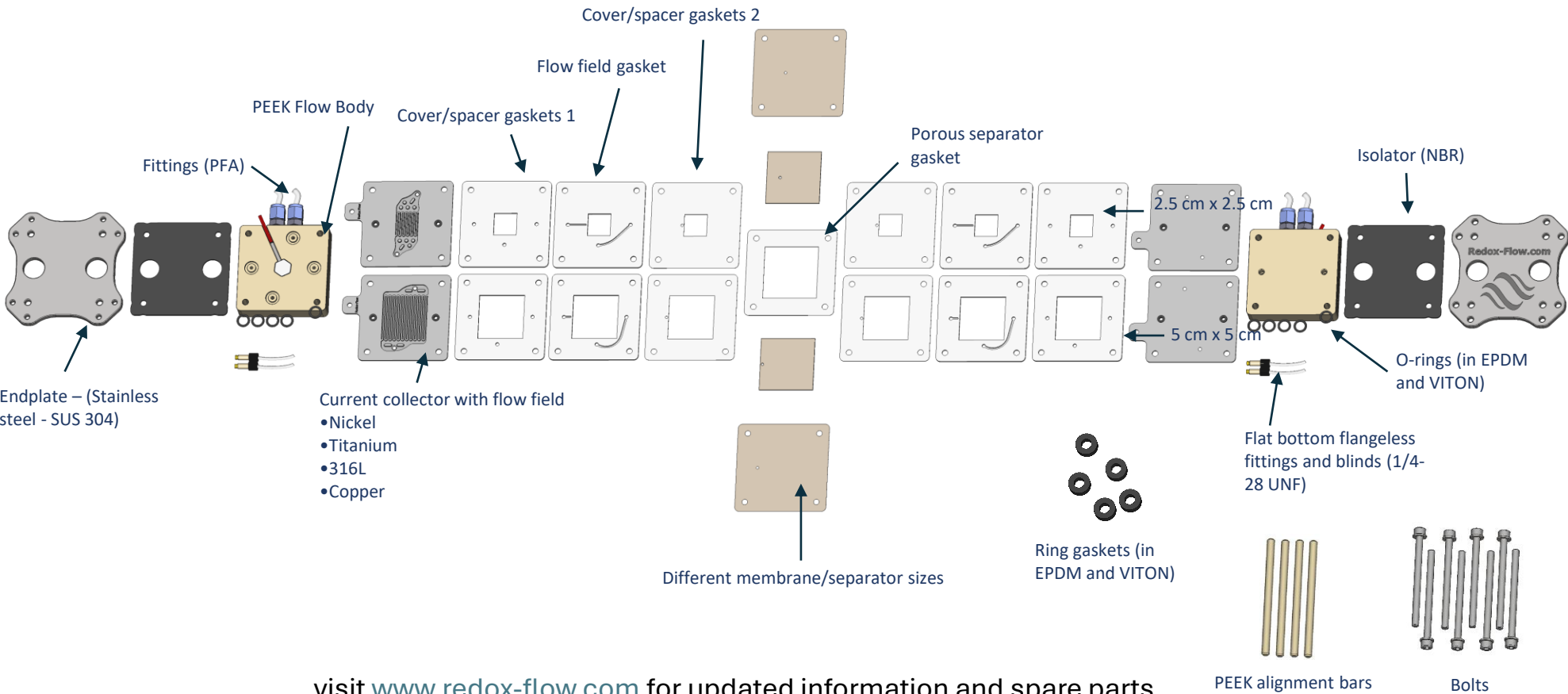

visit www.redox-flow.com for updated information and spare parts

Overview of variants & components included – current collectors with flat surface

General notes

- All gaskets are ordered separately - can be delivered in PTFE, EPDM and VITON
- All ring gaskets and O-rings in the cell package are delivered in both EPDM and VITON
- Current collector material and area is chosen with the order - Additional current collectors (area, material) and gaskets can be ordered separately whereby the cell can be used for different applications and with different active area
- Membranes and electrodes are not included in the cell package – can be ordered separately

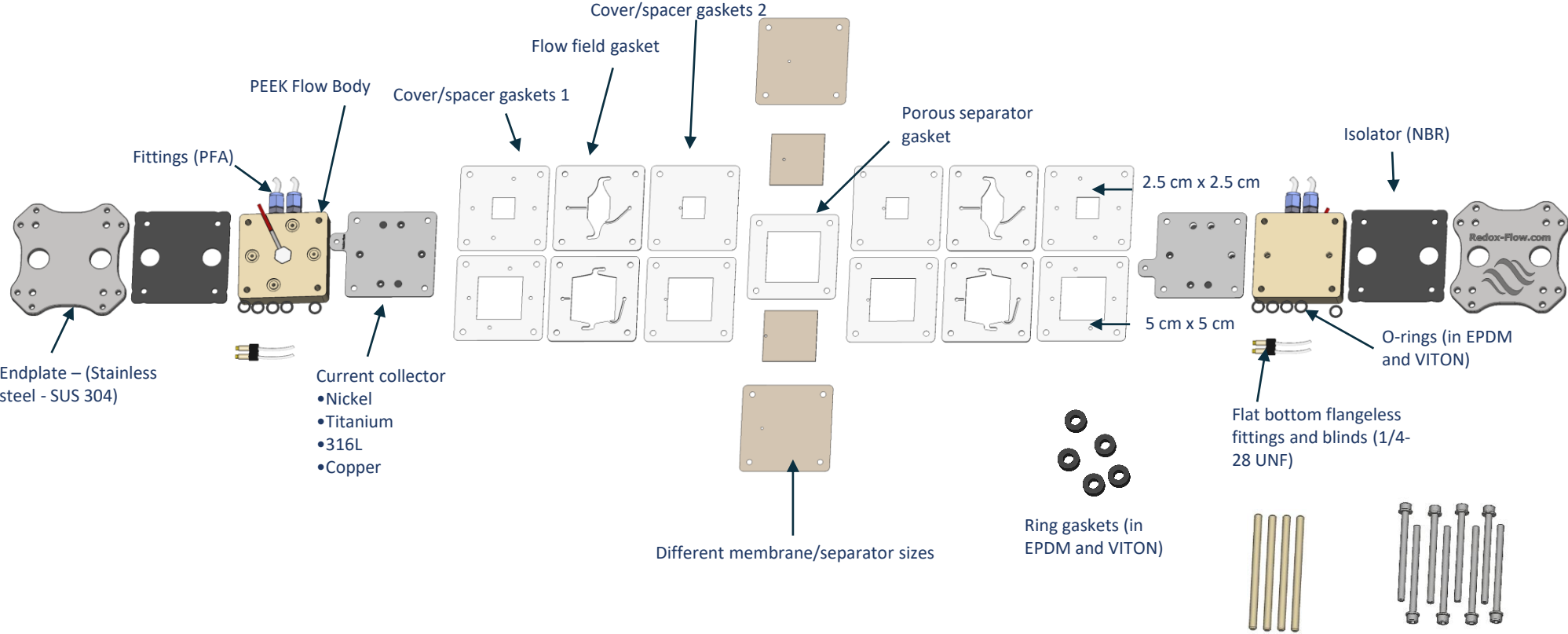

visit www.redox-flow.com for updated information and spare parts

PEEK alignment bars

Bolts

Working principles

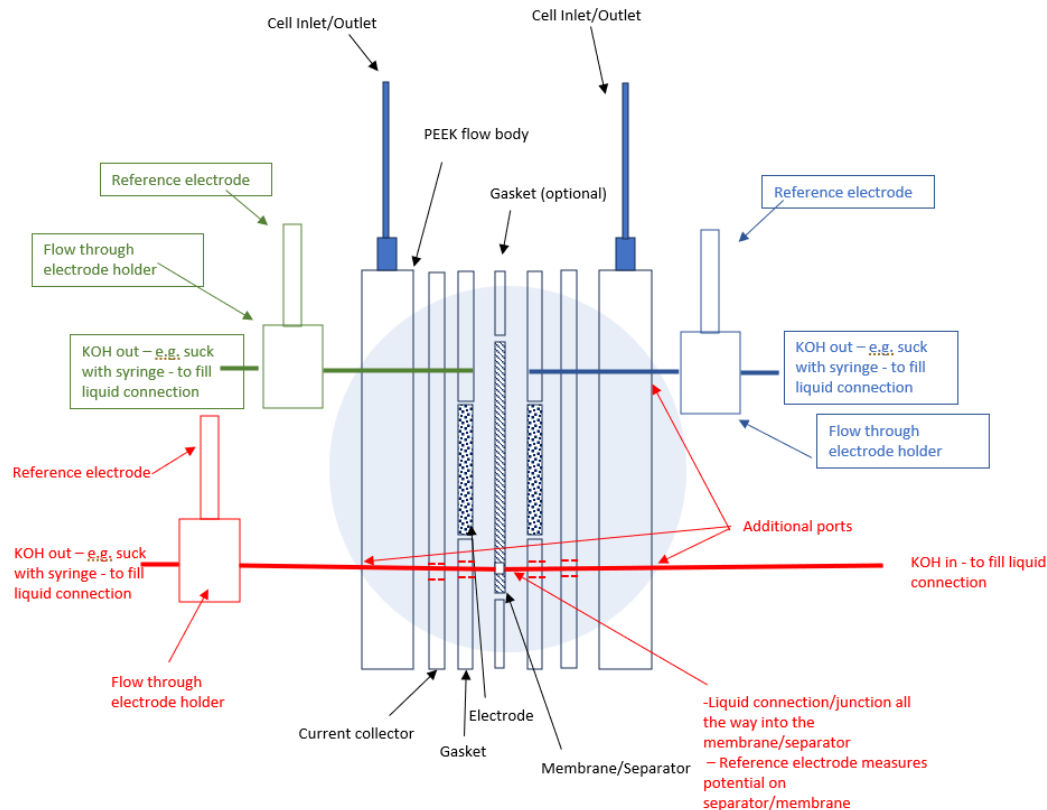

This cell is a variant of the X-cell, the main difference being additional ports for (reference) electrodes that are coupled by Luggin capillaries to relevant points inside the cell. The figure below is a schematic overview of the working principle.

The main difference between the standard X-cell and the one is highlighted by the blue shaded round area. Here additional ports on each side of the cell are included. This enables a hydraulic connection to (i) the separator/membrane (red) which can be used for a reference electrode measurement (Luggin capillary type) and (ii) hydraulic connections (blue and green) to the electrolyte stream just before it enters the electrodes.

Connection (i) is the typical one used for overpotential measurements, while connections (ii) are for more advanced operation. All three connections can be operated independent and if unused blocked with fittings that are delivered with the cell.

Working principles – current collectors with flow field

HYDRAULIC CONNECTION 1

Two additional ports on each side of the cell (four in total)

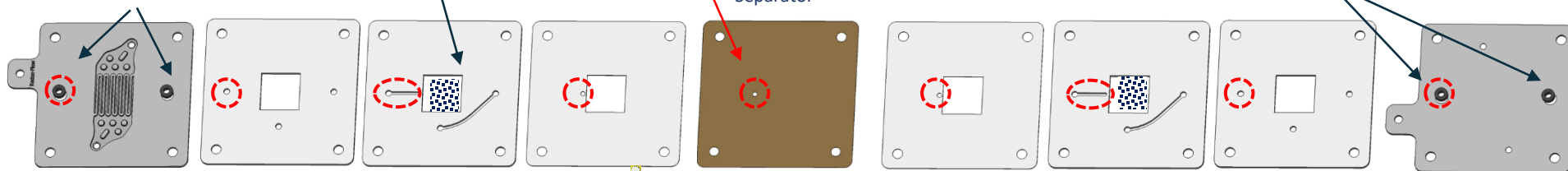

This option connects each side of the cell through a hydraulic channel that is in contact with the membrane/separator. Connecting a reference electrode to this channel allows measurement of electrode overpotentials in a manner similar to a three electrode setup where the reference electrode is placed in between the working and counter electrode.

HYDRAULIC CONNECTION 2

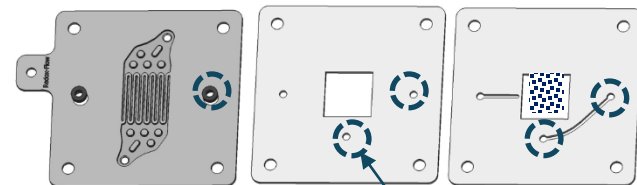

Liquid contact (Luggin capillary) to the liquid just before entering the electrode (cathode)

HYDRAULIC CONNECTION 3

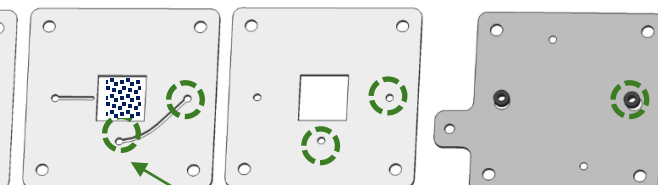

Liquid contact (Luggin capillary) to the liquid just before entering the electrode (anode)

Hydraulic connection 2 and 3 connects the outside port to the inlet flow channels on the anode and cathode side respectively. This can also be used for reference electrode measurements in some more specialized setups

SEE NEXT PAGE FOR VISUAL REPRESENTATION OF THE THREE HYDRAULIC CONNECTIONS/LUGGIN CAPILARIES

Working principles – current collectors with flat surface

HYDRAULIC CONNECTION 1

Two additional ports on each side of the cell (four in total)

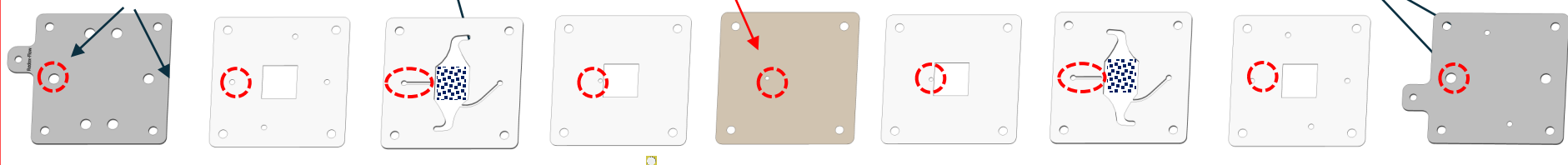

This option connects each side of the cell through a hydraulic channel that is in contact with the membrane/separator. Connecting a reference electrode to this channel allows measurement of electrode overpotentials in a manner similar to a three electrode setup where the reference electrode is placed in between the working and counter electrode.

HYDRAULIC CONNECTION 2

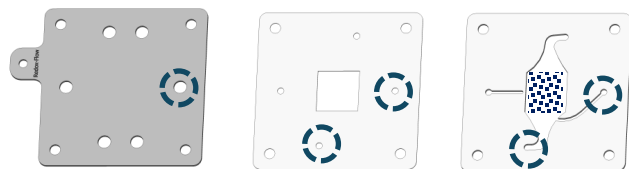

Liquid contact (Luggin capillary) to the liquid just before entering the electrode (cathode)

HYDRAULIC CONNECTION 3

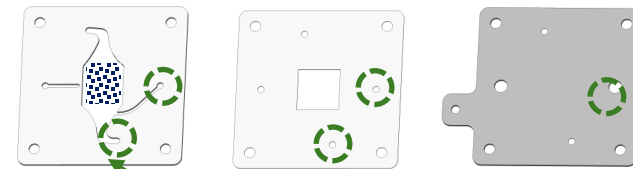

Liquid contact (Luggin capillary) to the liquid just before entering the electrode (anode)

Hydraulic connection 2 and 3 connects the outside port to the inlet flow channels on the anode and cathode side respectively. This can also be used for reference electrode measurements in some more specialized setups

SEE NEXT PAGE FOR VISUAL REPRESENTATION OF THE THREE HYDRAULIC CONNECTIONS/LUGGIN CAPILARIES

Working principles

Visual representation of the three hydraulic connections/Luggin capillaries. Arrows and colors shows the inlet/outlet of the channels. The green and blue hydraulic channels are connected to the main electrolyte flow, while the red is only in contact with the membrane/separator.

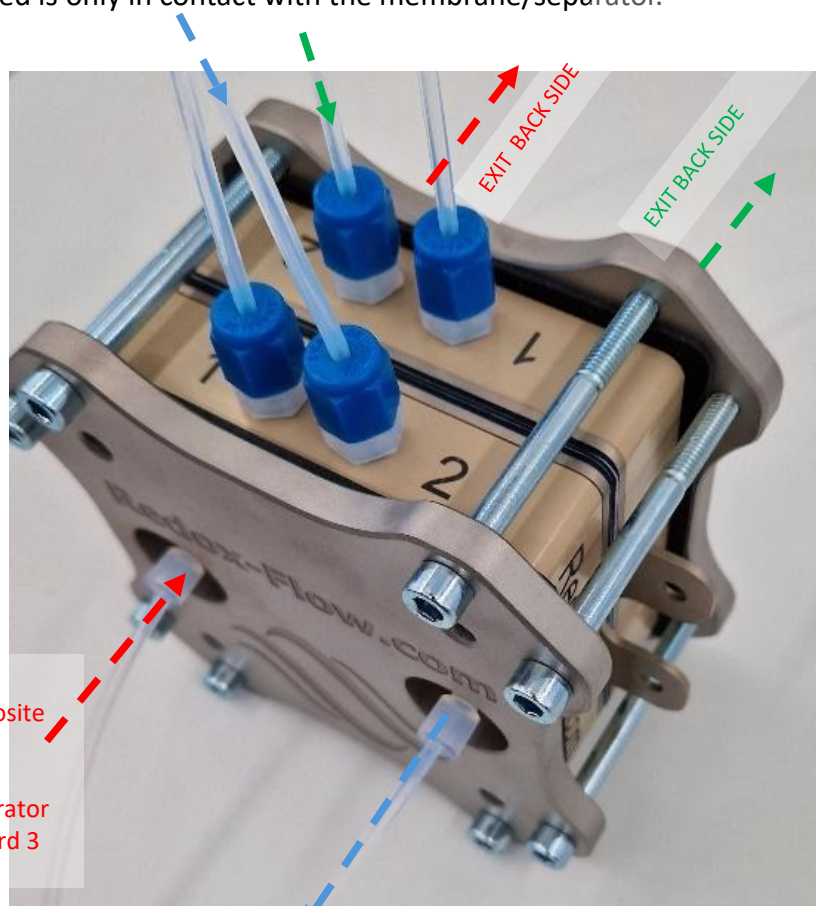

HYDRAULIC CONNECTION 1

- goes through the cell and exits on opposite side – in contact with membrane only
- can be used for reference electrode measurements on the membrane/separator (in between the electrodes as in standard 3 electrode configuration)

HYDRAULIC CONNECTION 2

- exits from the flow field and connects through the cell to top at port 2 (same as connection 3 but on opposite side)
- can be used for reference electrode measurement just before the electrolyte enters the electrode

HYDRAULIC CONNECTION 3

- exits from the flow field connects through the cell to top at port 2 (same as connection 2 but on opposite side)
- can be used for reference electrode measurement just before the electrolyte enters the electrode

Assembly – current collectors with flow field – go to p. 10 for detailed assembly

- Image below shows the overall assembly of the cell for both 2.5cm x 2.5cm and 5cm x 5cm active area.
- Assembly goes from left to right with the components turned and rotated as shown in the image.
- Following pages shows a detailed description

NOTE: The order of assembly does not strictly need to follow this manual. Depending on use and experience, assembly can deviate from this manual.

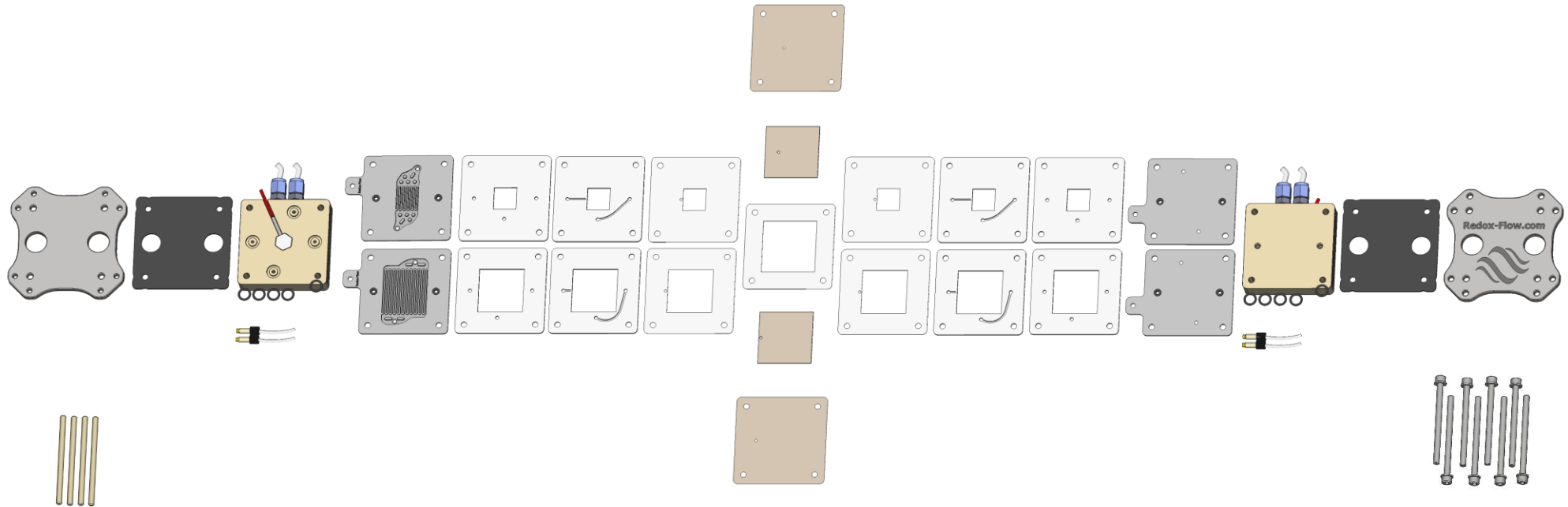

Assembly - current collectors with flat surface – go to p. 16 for detailed assembly

- Image below shows the overall assembly of the cell for both 2.5cm x 2.5cm and 5cm x 5cm active area.
- Assembly goes from left to right with the components turned and rotated as shown in the image.
- Following pages shows a detailed description

NOTE: The order of assembly does not strictly need to follow this manual. Depending on use and experience, assembly can deviate from this manual.

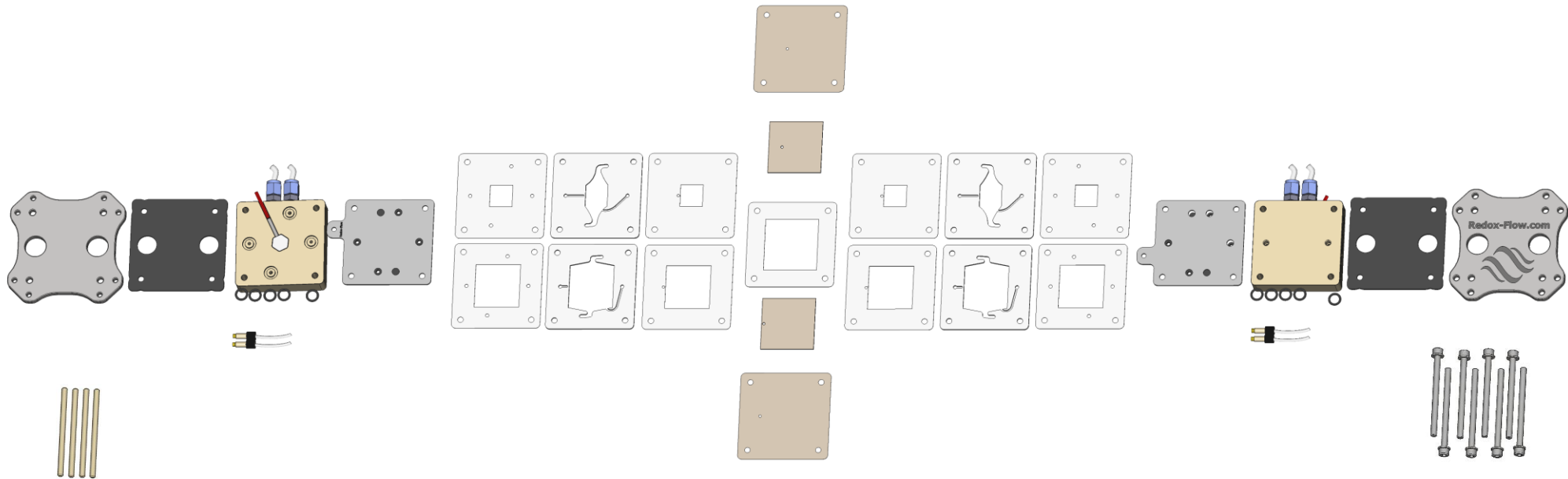

Assembly – current collectors with flow field

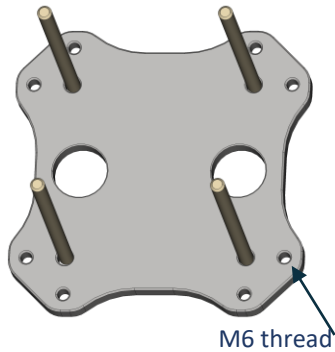
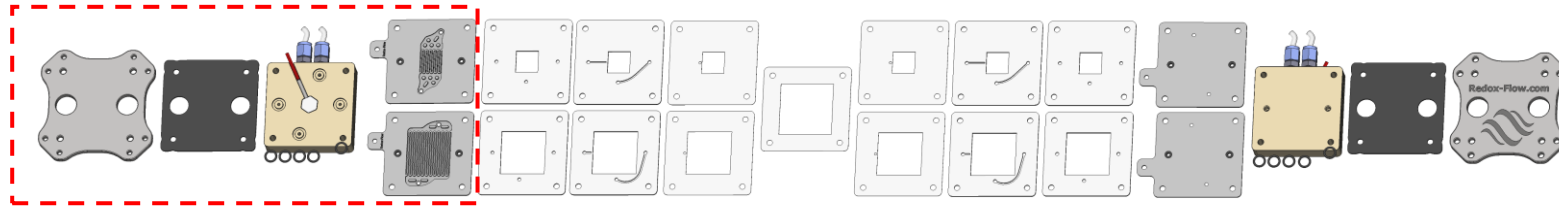

M6 thread

1. Threaded endplate is placed with logo downwards
2. All four alignment bars are placed in the holes in the endplate

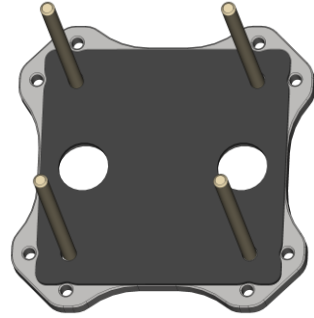

3. Isolator is placed on endplate

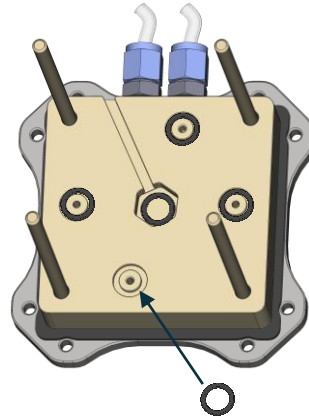

4. PEEK flow body is placed on isolator
5. All five O-rings are mounted in the PEEK flow body

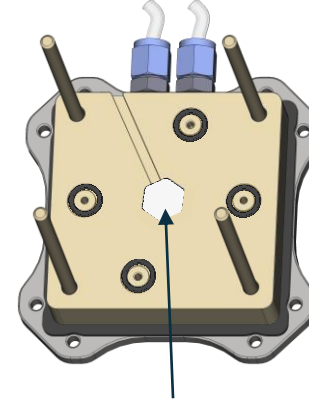

6. Alu thermometer holder is placed in the center hole
NOTE: The holder comes with three holes with different diameter.
-Choose the hole that fits your thermometer best
-Make sure the hole points toward the groove in the PEEK plate
-To ensure good thermal contact a little grease can be applied in the hole.

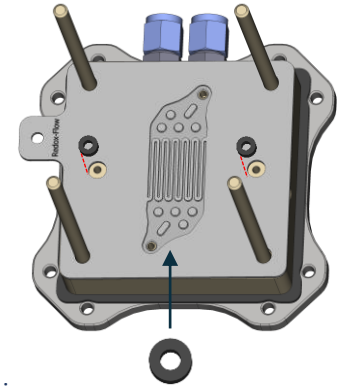

7. Current collector is placed on PEEK flow body

8. Ring gaskets with and without holes are mounted in current collector
NOTE: If port is unused, it can be blocked with ring gaskets without holes

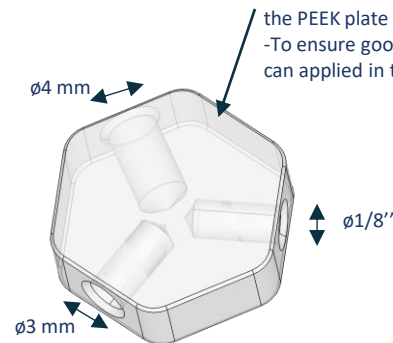

Assembly – current collectors with flow field

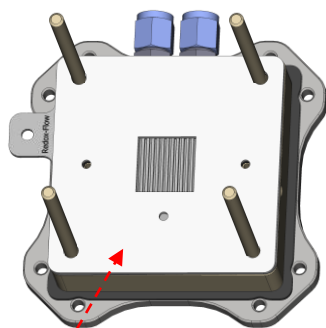
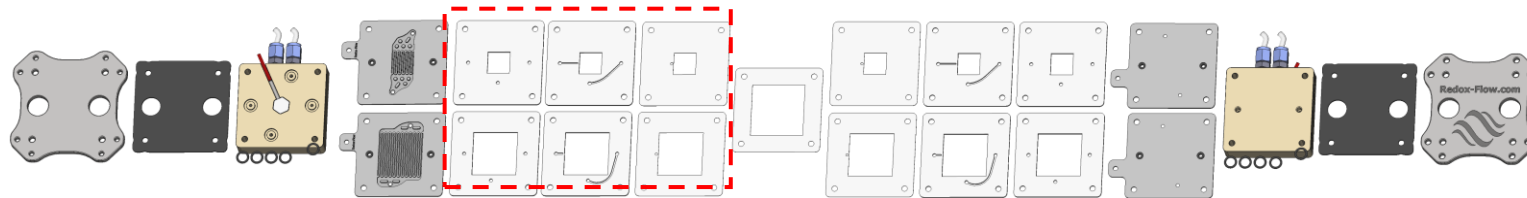

1. Cover/spacer gaskets 1 is placed on current collector

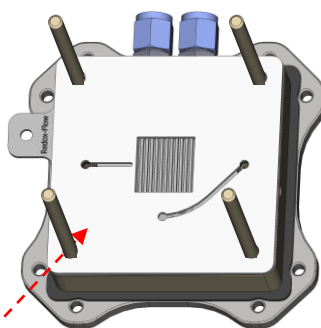

2. Flow field gasket is placed on cover/spacer gasket isolator

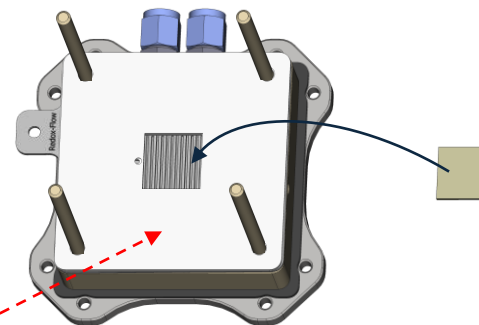

3. Cover/spacer gaskets 2 is placed on current collector isolator

4. Place electrode inside the gaskets

IMPORTANT NOTES

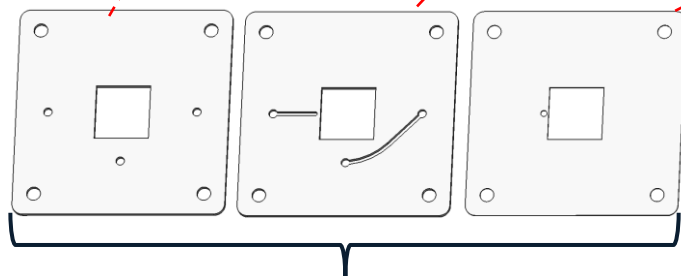

A. The final compressed thickness of the electrode is determined by the sum of the thicknesses of all stacked gaskets. Depending on the electrode varying compression is needed to ensure good electrical contact to the current collector

B. Several gaskets of all three types can be stacked on top of each of to fine-tune final compressed electrode thickness

C. It is recommended to have the *flow field gasket* as thick as possible and the two *cover/spacer gaskets* as thin as possible - This is to ensure that the hydraulic channels that connects to the reference electrode(s) are as large as possible.

Assembly – current collectors with flow field

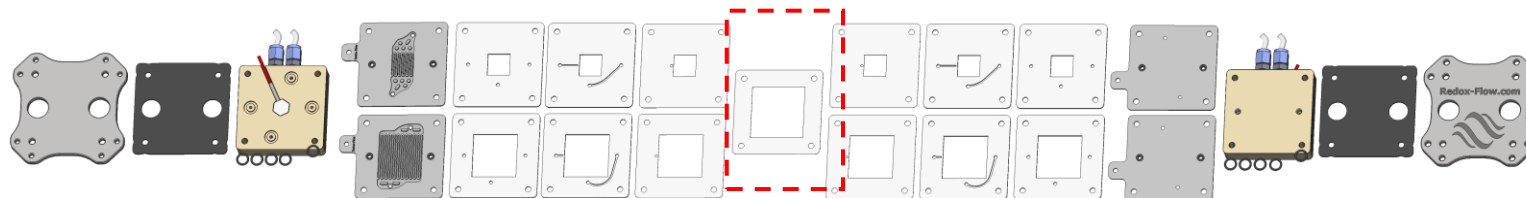

A. Assembly with porous separators

If the cell is operated with a porous separator use this section. If not go to section B on next page.

For porous separators it is in most cases necessary to include a *porous separator gasket* to prevent leaking out through the side of separator

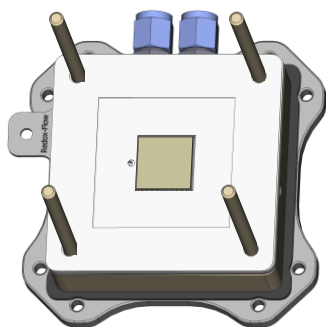

1. The *porous separator gasket* is placed on the previous gaskets NOTE: The open area of the *porous separator gasket* is 60mm x 60mm

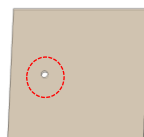

2. Cut a 60 mm x 60 mm separator

3. Pierce a small hole 1-2 mm in the separator (indicated by red circle). The hole must be exactly on top of the hole in the previous gasket

Note: *The Cover/Spacer Gasket 2* can be used as a template for where to pierce the hole

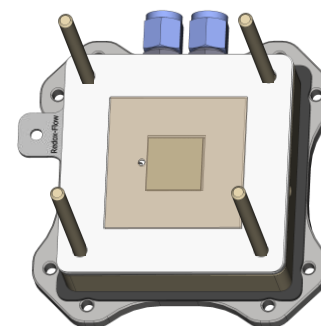

4. Place the separator inside the *porous separator gasket* is

IMPORTANT NOTES

- A. It is recommended to have a *porous separator gasket* thickness, that has the same thickness or slightly thinner than the thickness of the porous separator (e.g. within 0.0 mm to 0.1 mm)
- B. Several *porous separator gaskets* can be stacked on top of each of to fine-tune final thickness
- C. It is recommended to use either VITON or EPDM (compressible) as the main gasket and fine tune with PTFE gaskets. This will make sealing easier.

Assembly – current collectors with flow field

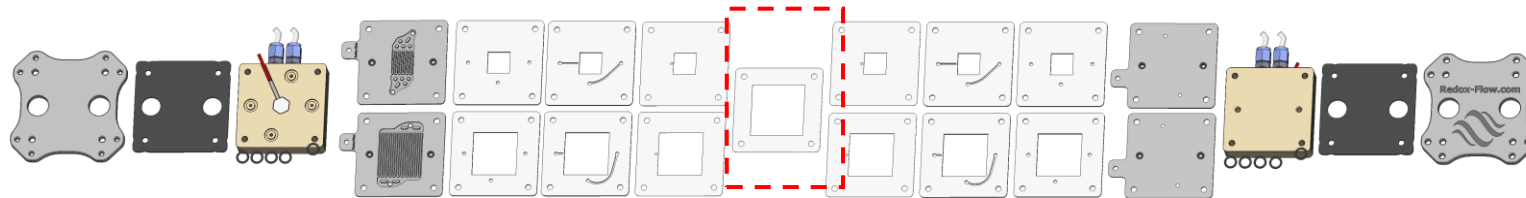

B. Assembly with dense & thin membranes

If the cell is operated with a dense and thin membrane a *porous separator gasket* is not necessary, and membranes of variable areas can be used.

1a. Use a membrane with a minimum dimension of 60 mm x 60 mm

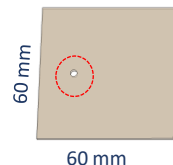

OR

1b. Use a membrane with the same outer dimensions as the gaskets (approximately 100 mm x 100 mm)

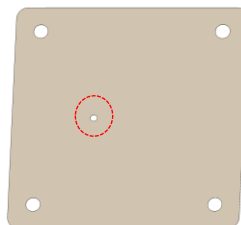

OR

1c. Use a membrane with any dimension in between 1a and 1b

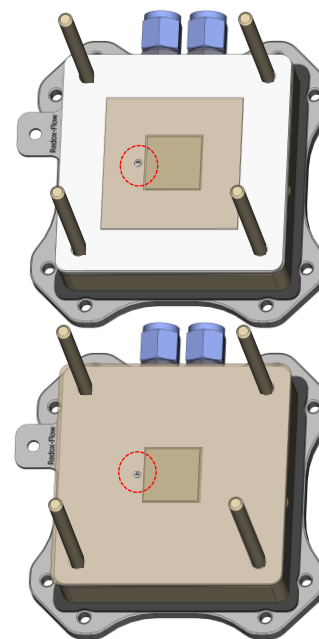

2. Pierce a small hole 1-2 mm in the separator (indicated by red circle). The hole must be exactly on top of the hole in the previous gasket

Note: *The Cover/Spacer Gasket 2* can be used as template for where to place the hole

Assembly – current collectors with flow field

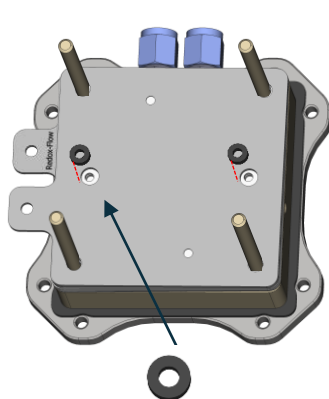
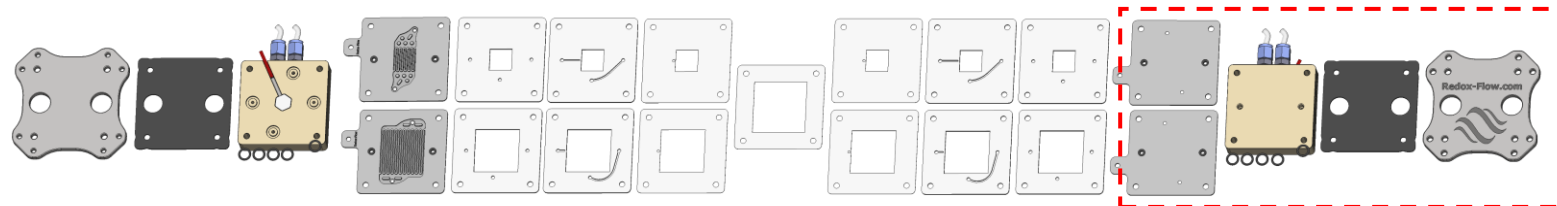

1. Current collector is placed on last *Cover/spacer gaskets 2*
NOTE: the flow field in the current collector must face downwards

2. Ring gaskets with holes are mounted in current collector
NOTE: If port is unused, it can be blocked with ring gaskets without holes

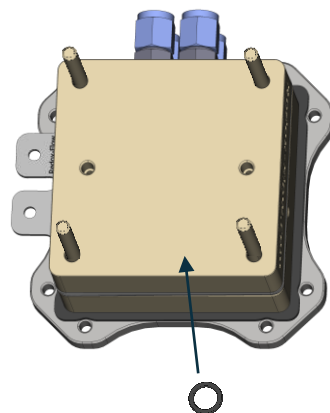

3. All four/five O-rings are mounted in the PEEK flow body (opposite side)
NOTE: If a thermometer is also used on this side, the thermometer holder should also be mounted.

4. PEEK flow body is placed on current collector

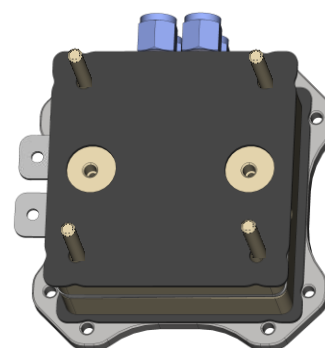

5. Isolator is placed on PEEK flow body

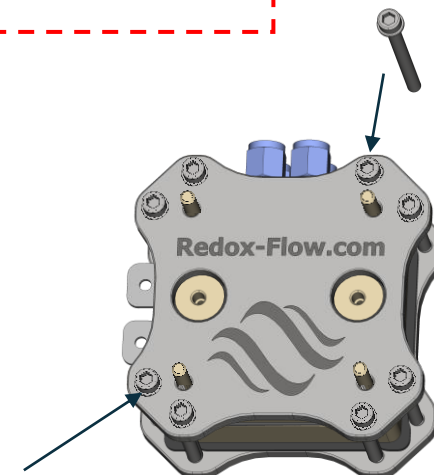

Hole for bolts in endplate is without a thread

6. Unthreaded endplate is placed with logo downwards

7. All eight bolts are placed in the outmost holes in the endplate
NOTE: Use bolts with correct length
NOTE: Keep alignment bars in the cell – they are taken out during the tightening of the cell

CELL IS NOW ASSEMBLED AND READY FOR TIGHTENING

Go to page 22

Assembly - current collectors with flat surface

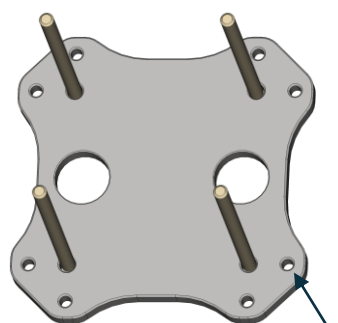
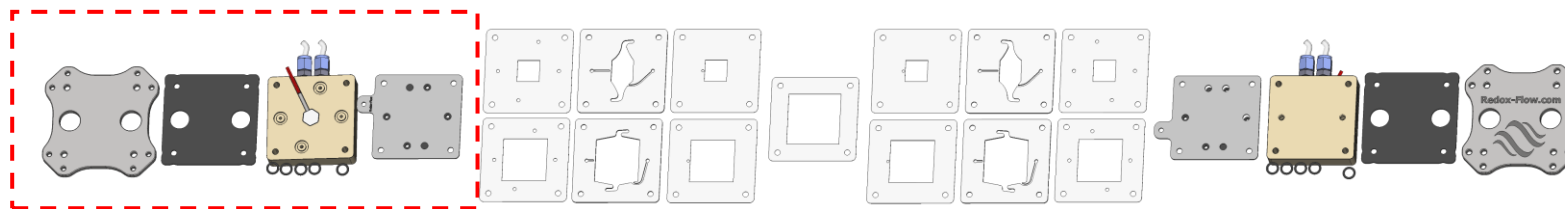

M6 thread

1. Threaded endplate is placed with logo downwards

2. All four alignment bars are placed in the holes in the endplate

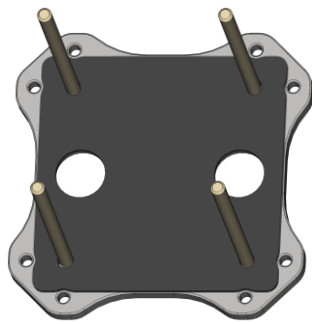

3. Isolator is placed on endplate

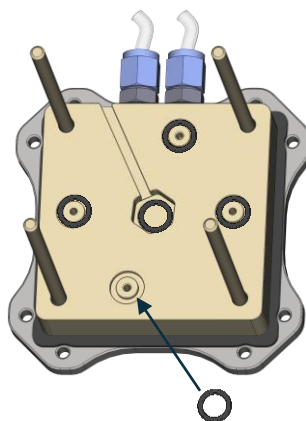

4. PEEK flow body is placed on isolator

5. All five O-rings are mounted in the PEEK flow body

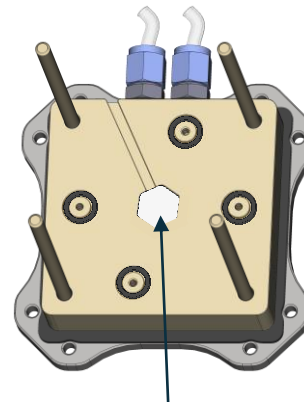

6. Alu thermometer holder is placed in the center hole

NOTE: The holder comes with three holes with different diameter.
-Choose the hole that fits your thermometer best
-Make sure the hole points toward the groove in the PEEK plate
-To ensure good thermal contact a little grease can be applied in the hole.

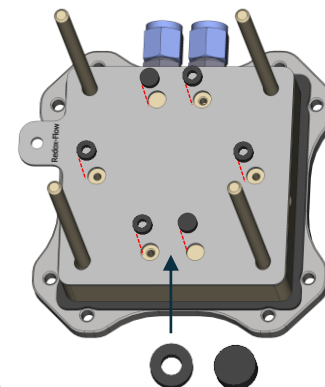

7. Current collector is placed on PEEK flow body

8. Ring gaskets with and without holes are mounted in current collector

NOTE: If port is unused, it can be blocked with ring gaskets without holes

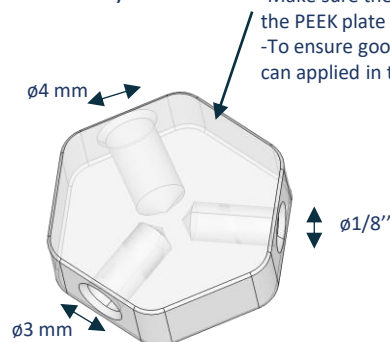

Assembly - current collectors with flat surface

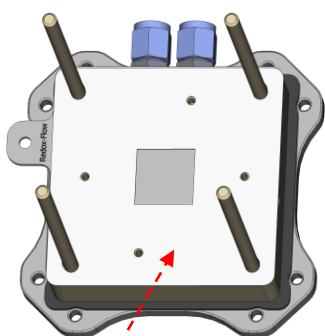
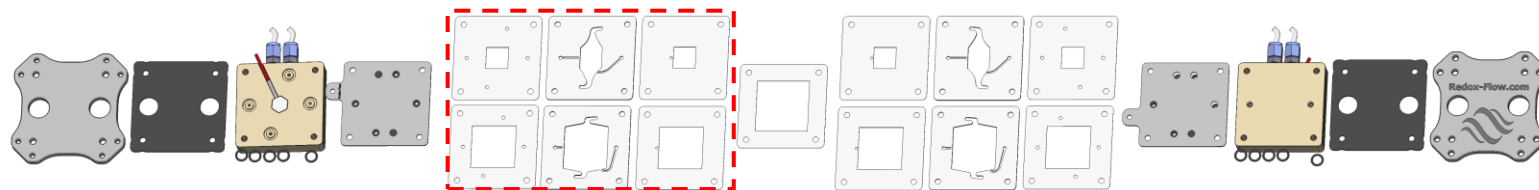

1. Cover/spacer gaskets 1 is placed on current collector

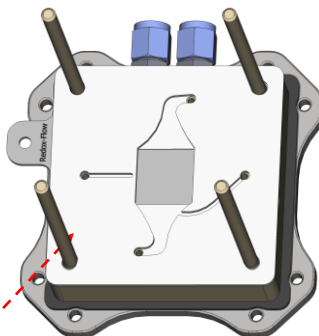

2. Flow field gasket is placed on cover/spacer gasket isolator

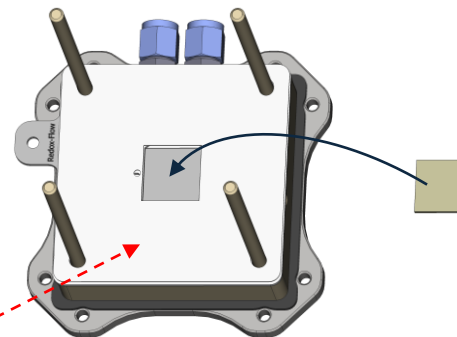

3. Cover/spacer gaskets 2 is placed on current collector isolator

4. Place electrode inside the gaskets

IMPORTANT NOTES

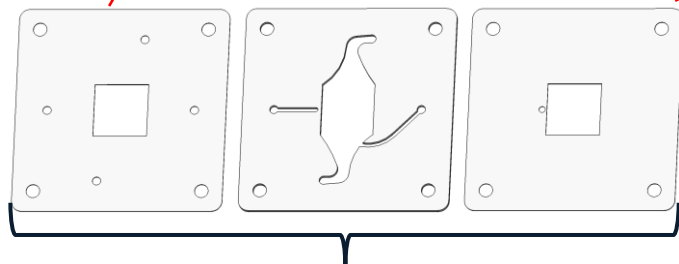

A. The final compressed thickness of the electrode is determined by the sum of the thicknesses of all stacked gaskets. Depending on the electrode varying compression is needed to ensure good electrical contact to the current collector

B. Several gaskets of all three types can be stacked on top of each of to fine-tune final compressed electrode thickness

C. It is recommended to have the *flow field gasket* as thick as possible and the two *cover/spacer gaskets* as thin as possible - This is to ensure that the hydraulic channels that connects to the reference electrode(s) are as large as possible.

Assembly - current collectors with flat surface

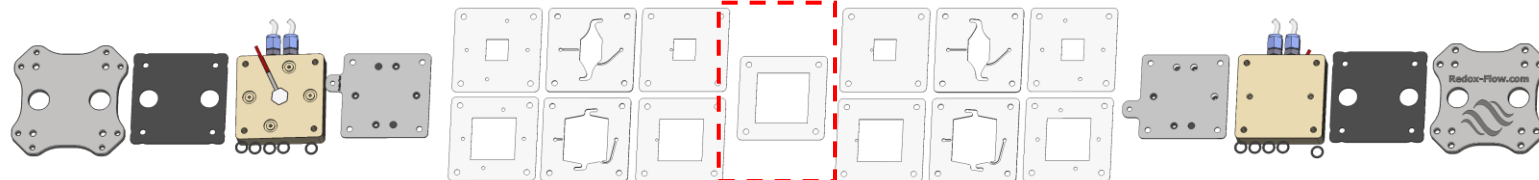

A. Assembly with porous separators

If the cell is operated with a porous separator use this section. If not go to section B on next page.

For porous separators it is in most cases necessary to include a *porous separator gasket* to prevent leaking out through the side of separator

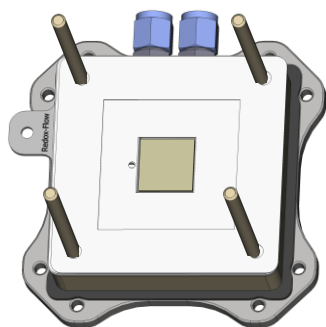

1. The *porous separator gasket* is placed on the previous gaskets NOTE: The open area of the *porous separator gasket* is 60mm x 60mm

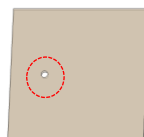

2. Cut a 60 mm x 60 mm separator

3. Pierce a small hole 1-2 mm in the separator (indicated by red circle). The hole must be exactly on top of the hole in the previous gasket

Note: *The Cover/Spacer Gasket 2* can be used as a template for where to pierce the hole

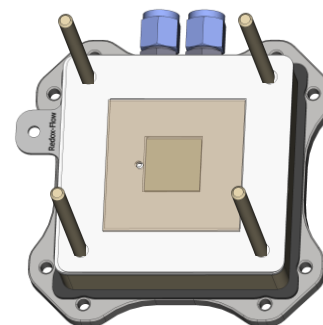

4. Place the separator inside the *porous separator gasket* is

IMPORTANT NOTES

- A. It is recommended to have a *porous separator gasket* thickness, that has the same thickness or slightly thinner than the thickness of the porous separator (e.g. within 0.0 mm to 0.1 mm)
- B. Several *porous separator gaskets* can be stacked on top of each of to fine-tune final thickness
- C. It is recommended to use either VITON or EPDM (compressible) as the main gasket and fine tune with PTFE gaskets. This will make sealing easier.

Assembly - current collectors with flat surface

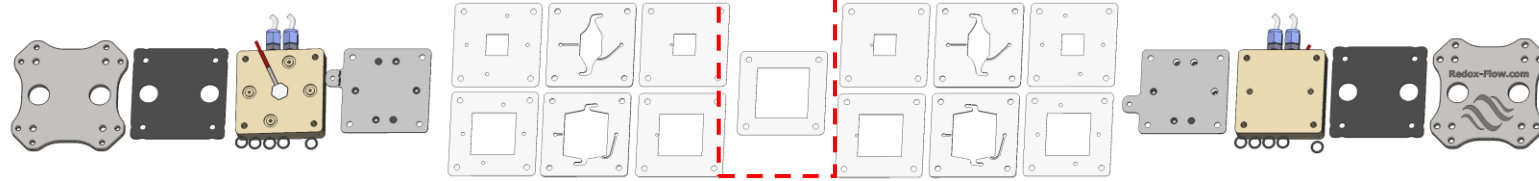

B. Assembly with dense & thin membranes

If the cell is operated with a dense and thin membrane a *porous separator gasket* is not necessary, and membranes of variable areas can be used.

1a. Use a membrane with a minimum dimension of 60 mm x 60 mm

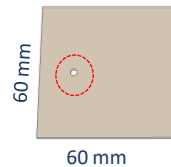

OR

1b. Use a membrane with the same outer dimensions as the gaskets (approximately 100 mm x 100 mm)

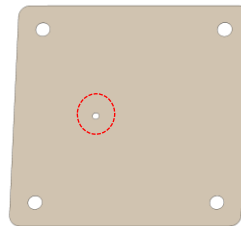

OR

1c. Use a membrane with any dimension in between 1a and 1b

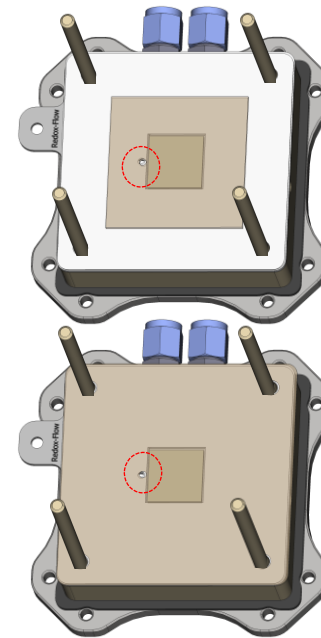

2. Pierce a small hole 1-2 mm in the separator (indicated by red circle). The hole must be exactly on top of the hole in the previous gasket

Note: *The Cover/Spacer Gasket 2* can be used as template for where to place the hole

Assembly

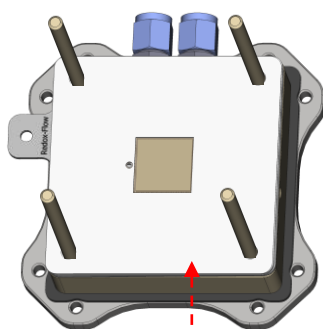
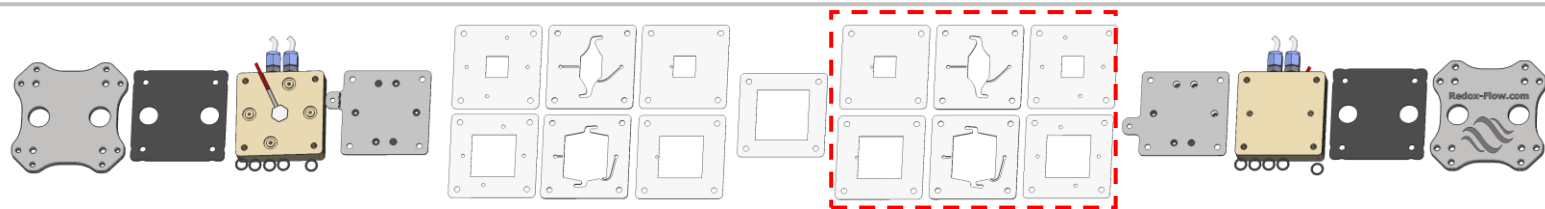

1. Cover/spacer gaskets 2 is placed on membrane

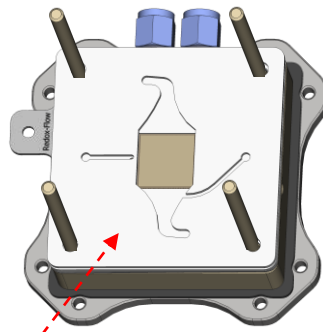

2. Flow field gasket is placed on cover/spacer gasket isolator

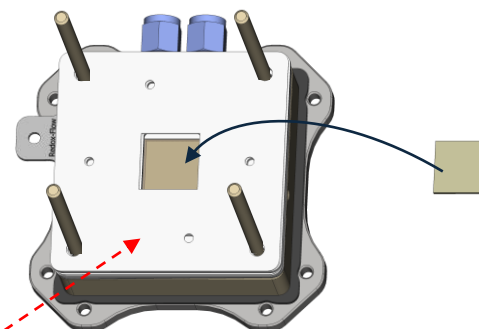

3. Cover/spacer gaskets 1 is placed on Flow field gasket

4. Place electrode inside the gaskets

IMPORTANT NOTES

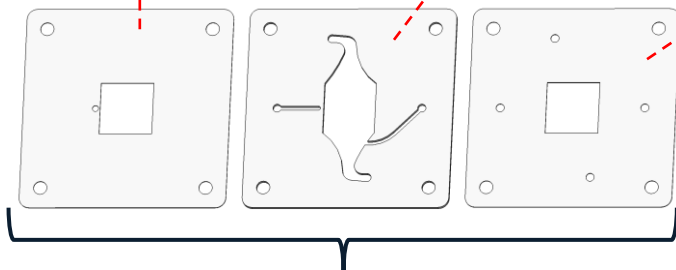

A. The final compressed thickness of the electrode is determined by the sum of the thicknesses of all stacked gaskets. Depending on the electrode varying compression is needed to ensure good electrical contact to the current collector

B. Several gaskets of all three types can be stacked on top of each of to fine-tune final compressed electrode thickness

C. It is recommended to have the *flow field gasket* as thick as possible and the two *cover/spacer gaskets* as thin as possible - This is to ensure that the hydraulic channels that connects to the reference electrode(s) are as large as possible.

Assembly – Final assembly

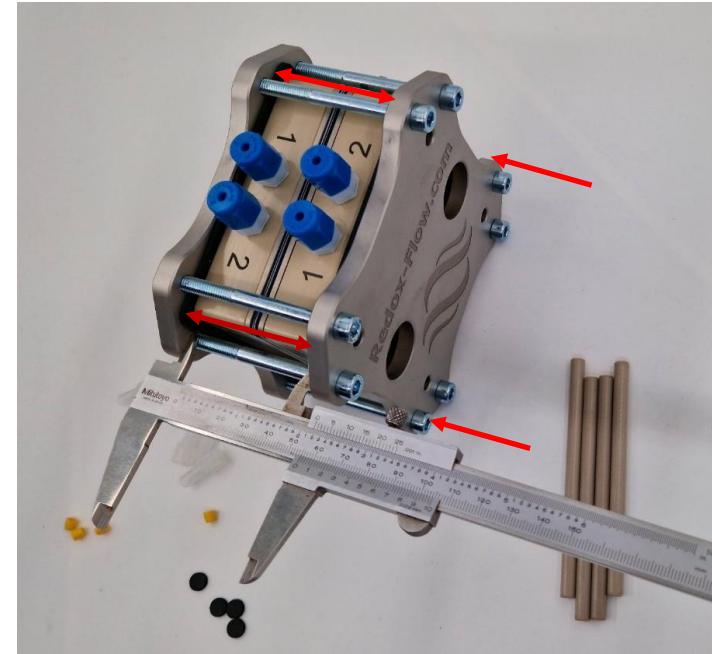
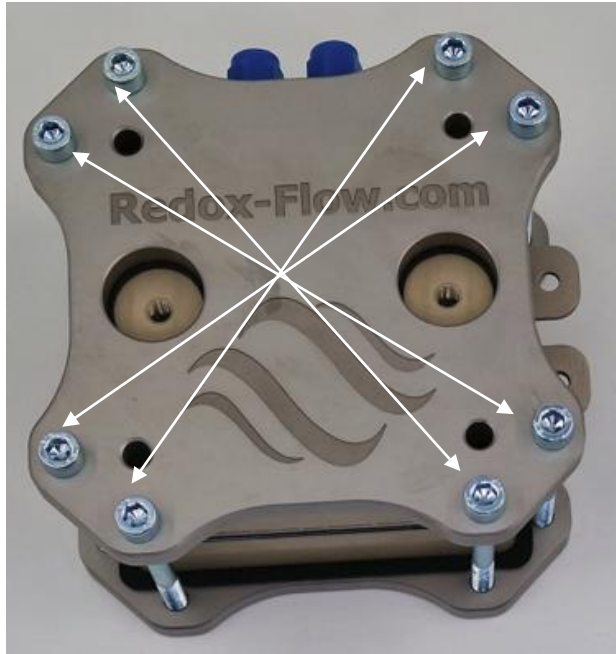

STEP 1

- Hex bolts are cross tightened up to 9 Nm.
- Alignment bars are removed before cell is completely tightened - if left in the cell, there is a (small) risk of leaks inside channels for the alignment bars

IMPORTANT NOTES

- Measurement with caliper is paramount for a tight sealing – It is not a high torque that seals the cell, it is a correct alignment of the flow bodies. Up to 9 Nm max. Recommended to experiment 5-8 Nm, seeing what is the best fit.

STEP 2

- Quality of the cross tightened is checked by measuring the distance between the endplates at all four corners with a caliper
- The distance should not vary more than 0.1-0.2mm
- NOTE: Step 1 and 2 can be performed iteratively.

Application notes – Unused ports



If the ports in the cell are not used, the cell can be operated as the standard X-cell. Ports can be sealed by the blind fittings (and ring gaskets without holes – see assembly)

Application notes – Electrical connections

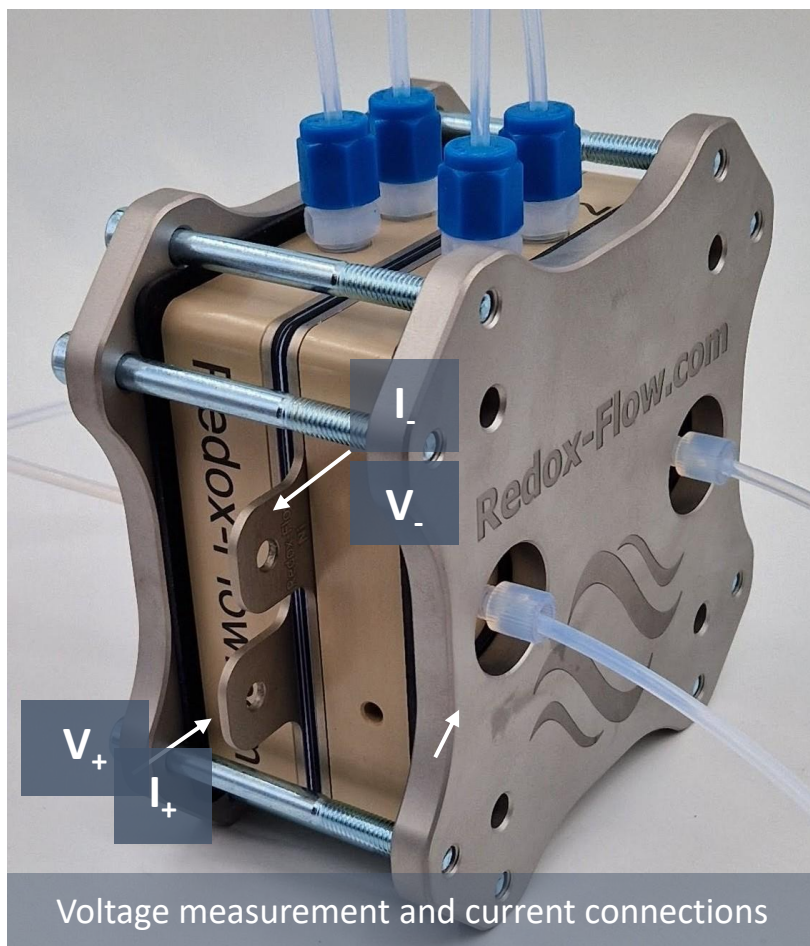

IMPORTANT - It is paramount for safety and reproducible data that the wires for

- Electrical current (I_+ and I_-) are well connected on the current collectors e.g. with cable lugs, bolts or other recognized solutions for making proper electrical connections

NOTE: Poorly connected current wires will lead to significant contact resistance between the wire and current collectors. For high current operation (e.g. > 1 A) the contact resistance (even small ones) can lead to significant heating in the contact points.

- Voltage measurements (V_+ and V_-) are mounted on the current collectors to ensure a proper 4-wire configuration

NOTE: As the wires for voltage measurement does not carry any electrical current, there are no strict requirements for the quality of the connection and can e.g. be connected with crocodiles or similar

Application notes – Temperature sensors

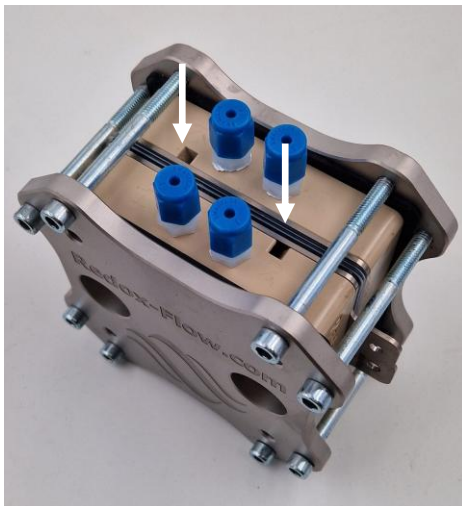

Holes for thermometers

Temperature sensor

- In each of the PEEK flow bodies there are holes with direct access to the aluminum thermometer holder. The distance from the PEEK surface to the bottom of the thermometer holder is approximately 55 mm
- The aluminum holder is pressed up against the metal current collector. This ensures very good thermal contact whereby
 - The temperature can be measured fast (very short time delay on temperature changes)
 - The temperature can be measured very precise
- To increase the thermal contact a little grease can be applied to the head of the thermometer or inside the hole of the thermometer holder

VERY IMPORTANT: The thermometer holder is in direct metallic contact with the bipolar plate and will for this reason have the same applied electrical potential as the bipolar plate. **Here is it extremely important that the electrical circuit of the thermometer is electrically isolated from the metal parts.** This is the case for most thermometers with housings (even metallic ones) but can be tested by measuring the electrical resistance with a multimeter between thermometer housing and thermometer measurement wires. However, this is not the case for bare/unprotected thermometer, these can be isolated with tape, shrinking tube or similar.

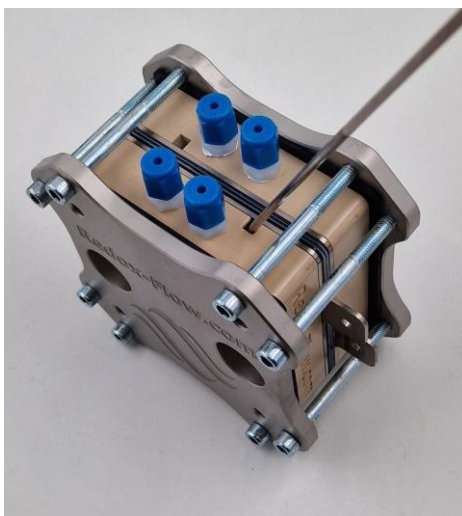

Mounting with rigid thermometer

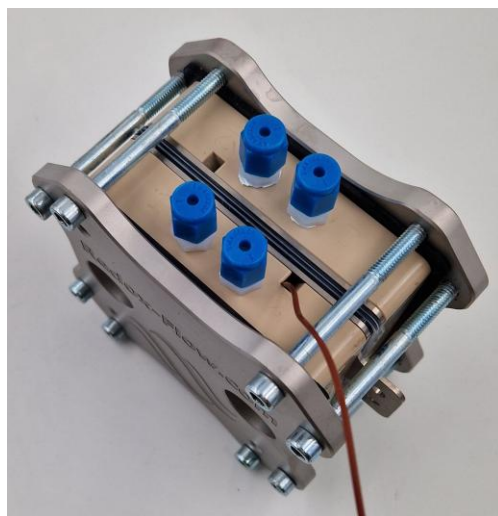

Mounting with wire thermometer

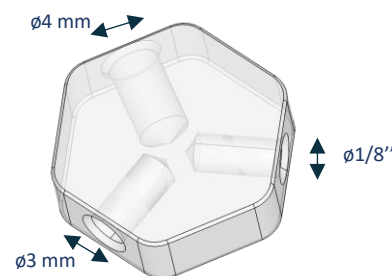

Thermometer holder

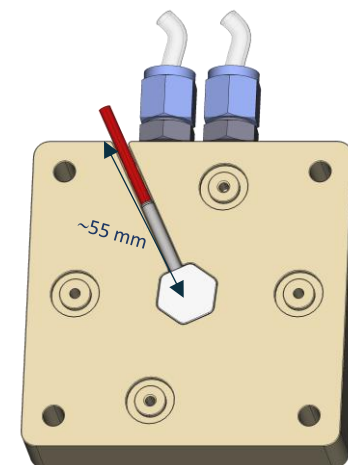

Thermometer, holder & PEEK block (metal current collector is mounted on top)

Application notes – Hydraulic connections

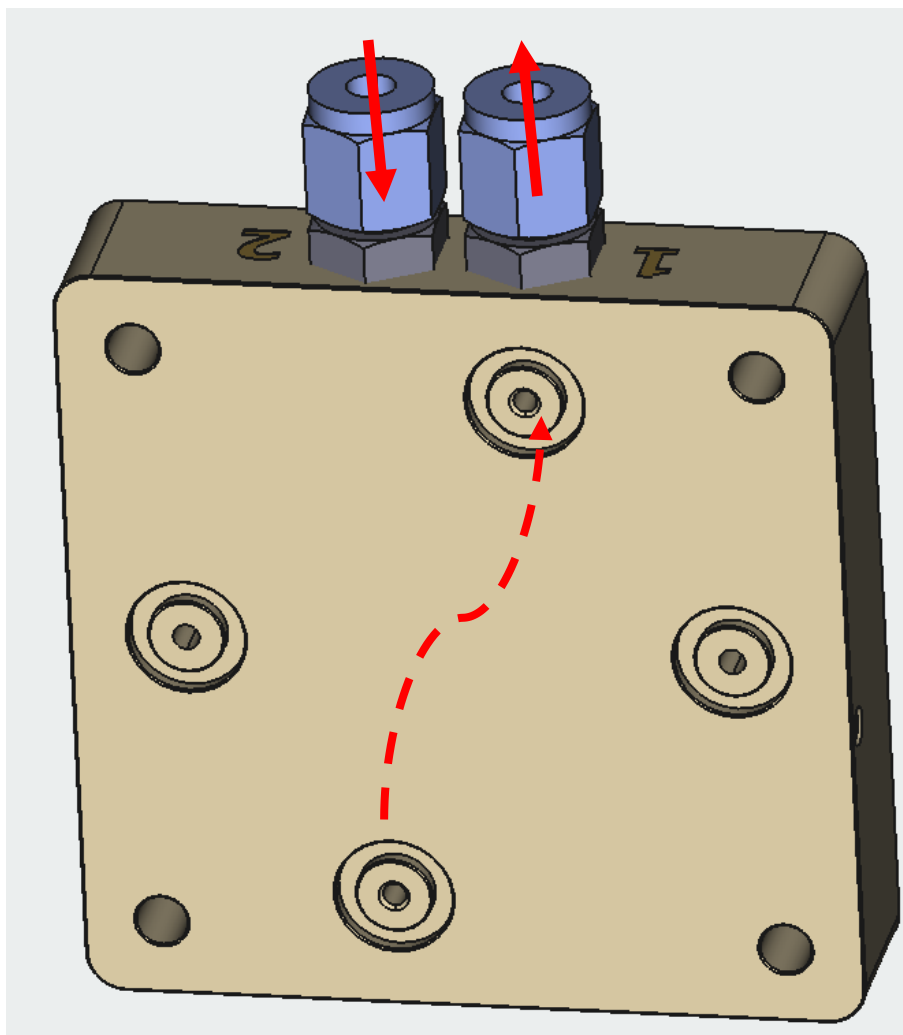

For normal operation it is recommended to use **port 1** as outlet of for the liquid and **port 2** as the inlet for the liquid

NOTE: With this configuration the liquid enters at the bottom and exits at the top. This makes removal of bubbles easier.

Application notes – Reference electrodes

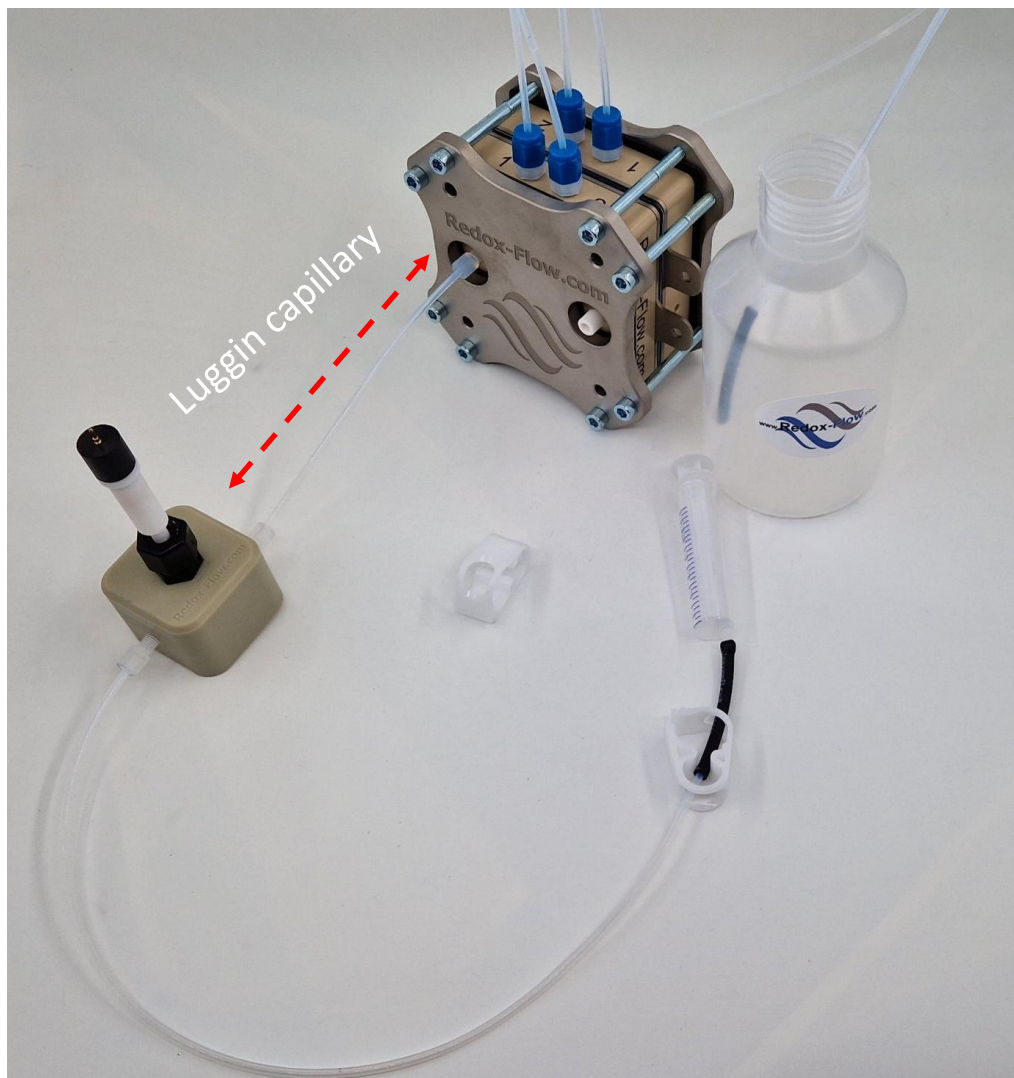

Luggin capillary - Galvanic connection to the reference electrode is ensured by connecting one port to an electrolyte beaker (back side on picture). Connecting the other port (front side on the picture) to the reference electrode holder. Electrolyte is sucked through the cell with a syringe.

NOTE: Reference electrode and holder is not included with the cell. See www.redox-flow.com for options on electrode holds and accessories.